



Installation and Operational Manual

May, 2019

Table of Contents

Introduction	2
Safety	2
Track Installation	2
Rail Lumber	2
Choosing a Track Route	2
Installing the First Rail	3
Installing the Corner Rail Assembly	5
Installing an Adjustable Corner Assembly	7
Tool-less Track Bridge	10
Limit Switch Stop	13
End Stop	13
Installing the Trolley	15
Operation	16
Charging the Battery	16
Maintenance	16
Programing the Remote	16
Warranty Coverage	17
Warranty Is Void If:	17
Getting Warranty Service	17
Contact Information	17

Introduction

Thank you for purchasing the Chicken Reaper trolley system. Please read this manual carefully before beginning installation or use. Proper installation and use will ensure that the Chicken Reaper will provide many years of reliable service.

Safety

It is critical that all safety guidelines included in this manual are followed. Failure to follow safety guidelines could result in property damage, serious injury or death.

- Installing the track system too close to a heater could result in a fire hazard. Check with the heater manufacturer to make sure the track system is outside the heater's recommended clearances.
- Routinely inspect the track system and trolley for any loose hardware.
- The trolley is intended for transporting dead birds, feed or other supplies. **NEVER RIDE IN THE TROLLEY!**
- Use great care when detaching or attaching the dump box or bucket tray from the trolley to ensure the trolley doesn't unhook from the rail.
- Ensure that bystanders and obstacles are clear of the track route before operating the trolley
- Always turn the Power Switch OFF when you are finished using the Chicken Reaper.
- Ensure that the Charging Cord is disconnected before operating the Chicken Reaper.
- **NEVER** operate the Chicken Reaper unattended!
- **NEVER** operate the Chicken Reaper at more than 50% speed while navigating a corner!

Track Installation

Proper track installation is key to having a safe and functional system. Please review the instructions below closely before beginning. If you have any questions, please contact your local dealer or the manufacturer before beginning the installation process.

Rail Lumber

The Chicken Reaper is designed to operate on a 2" x 6" x 16' or 20' Yellow Pine rail. Using longer 2 x 6's results in fewer joints in the track which speeds up the installation process. Contact your local lumber supplier to purchase the needed amount of Number 1 Yellow Pine boards. Good quality lumber will make the installation process much easier. Twisted or warped boards will make it impossible to install a level and straight track system.

Choosing a Track Route

The Chicken Reaper can be installed as a single rail system or a complete loop system. You will need to decide what setup will best serve your needs.

After you have identified the track system (single rail or loop) that you will be installing, you will need to choose the track route. Pay attention to the location of feeder lines, water lines, winch cables, electrical lines, heaters, etc. as you choose a route. Ensure that your completed track will have adequate clearance from all existing equipment. Failure to do so could result in damage to The Chicken Reaper and/ or existing equipment.

Normally, the poly ceiling straps can be used as a guide for installing the truss brackets in a straight line. If not, use a string line to make sure the truss brackets are in a straight line. On a Loop System, the Hanger Brackets **MUST** be installed on the inside of the track.

Installing the First Rail

It is important to get the first rail positioned properly so that remaining track holds out. The rolled steel tube Corner Rails are designed for 48" truss centers. If your truss centers are different, you will need to install cross-members to support the end track. Always install the linear track first before installing the corners and end track.

1. Choose the truss that the end track will run below and move "in" to the next truss to install the first Truss Bracket.
2. **Make sure the Truss Bracket is oriented as shown below** and secure with two GKR fasteners. It is critical that the two GRK fasteners are properly secured to the truss. **Failure to do so could result in serious injury or even death!**

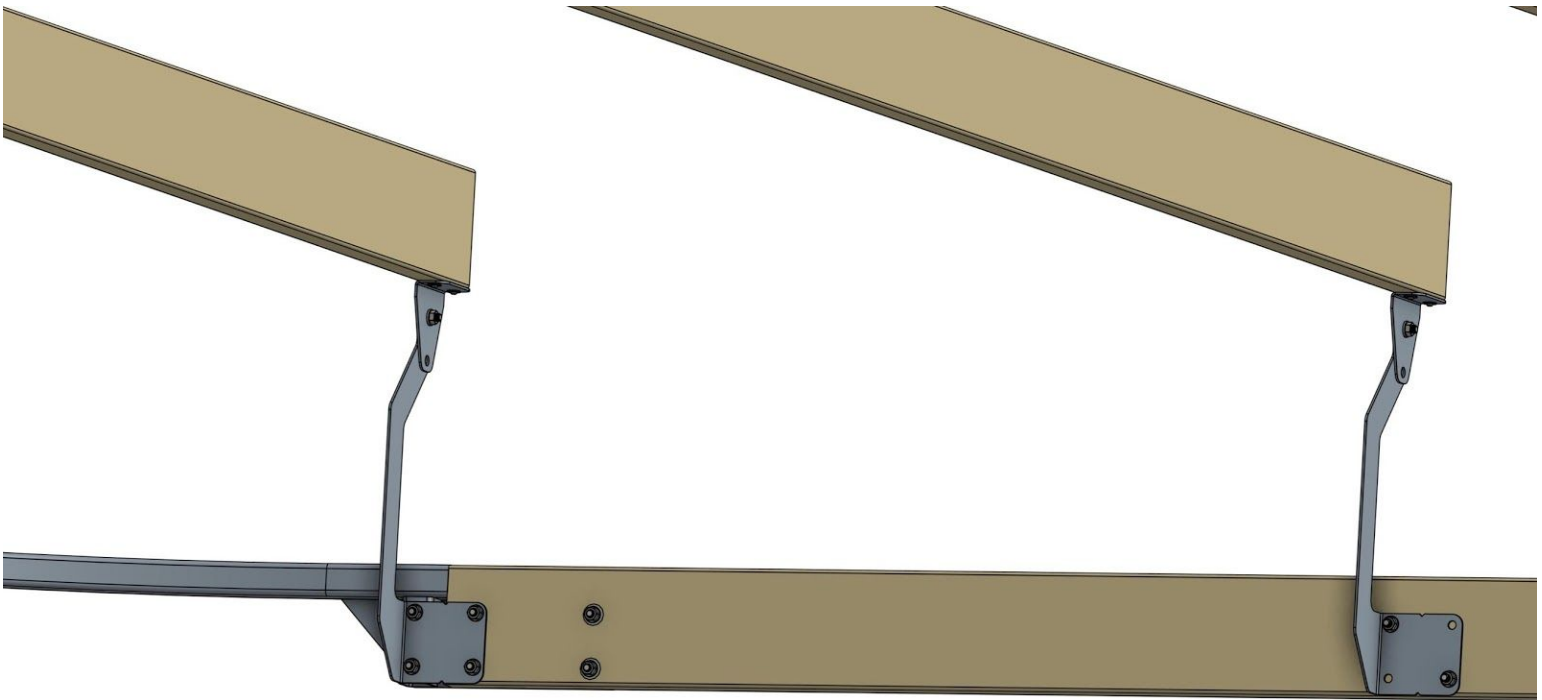

3. There are (3) height settings for attaching the Hanger bracket to the Truss Bracket. This adjustment gives 7" or 8" or 9" of clearance from the top of the Trolley wheel to the ceiling. Use the setting that will give you the needed clearance for any winch cables, feeder lines, etc. that the track will cross. Using a 3/8" x 3/4" carriage bolt and flange nut, loosely attach a Hanger Bracket to the Truss Bracket. Do not tighten yet.

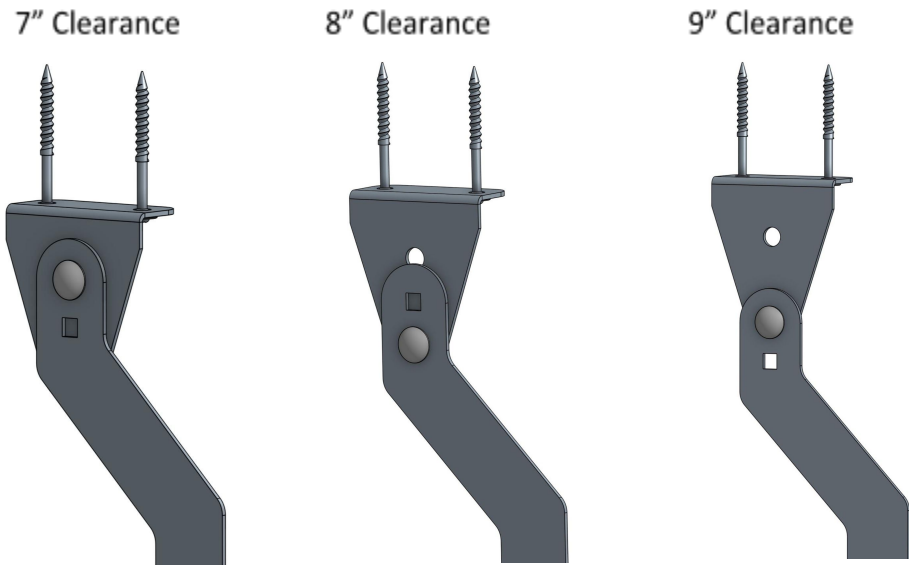

4. Repeat steps 2 & 3 to install an additional (4) Truss Brackets, one on every truss.
5. Using clamps, secure a 2" x 6" x 16' rail to the first and last Hanger Brackets. The rail needs to be flush with the bottom of each Hanger Bracket. The end of each rail should be aligned to the small V notch (shown below) in the Hanger Bracket. It is important that this rail is exactly 16' in length. Trim if necessary.

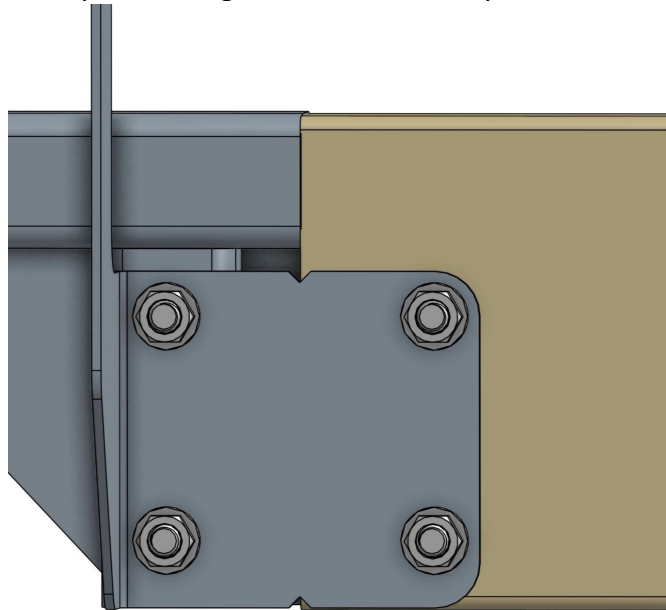

6. Using a 25/64" drill bit, drill holes for the 3/8" x 2-1/4" carriage bolts using the Hanger Brackets as a template. (4) bolts will be used at each joint and (2) bolts in all other Hanger Brackets.
7. Secure the rail to the Hanger Brackets using 3/8" x 2-1/4" carriage bolts and flange nuts. Tighten until the carriage head is pulled into the wooden rail.

8. Use a torpedo level to level each Hanger Bracket and then tighten the 3/8" x 3/4" Truss Bracket bolt.
9. Temporarily attach a diagonal wooden brace from the rail up to a truss to prevent the track from shifting linearly as the rest of the track is installed. This only needs to be installed on the first rail of each linear run. Remove this brace when the track installation is completed.
10. This completes the installation of the first rail.
11. Repeat the steps above to install the remaining linear track.

Installing the Corner Rail Assembly

1. Remove the 3/8" x 2-1/4" carriage bolts from the end Hanger Bracket.
2. Attach one end of the Corner Rail to the Hanger Bracket using (4) 3/8" x 2-1/4" carriage bolts and flange nuts.
3. Drill (2) additional 25/64" holes in the rail using the Corner Rail plate as a template. Attach with (2) 3/8" x 2-1/4" carriage bolts, flat washers and flange nuts.
4. When the first end of the Corner Rail is attached to the linear rail, it should look like the image below.

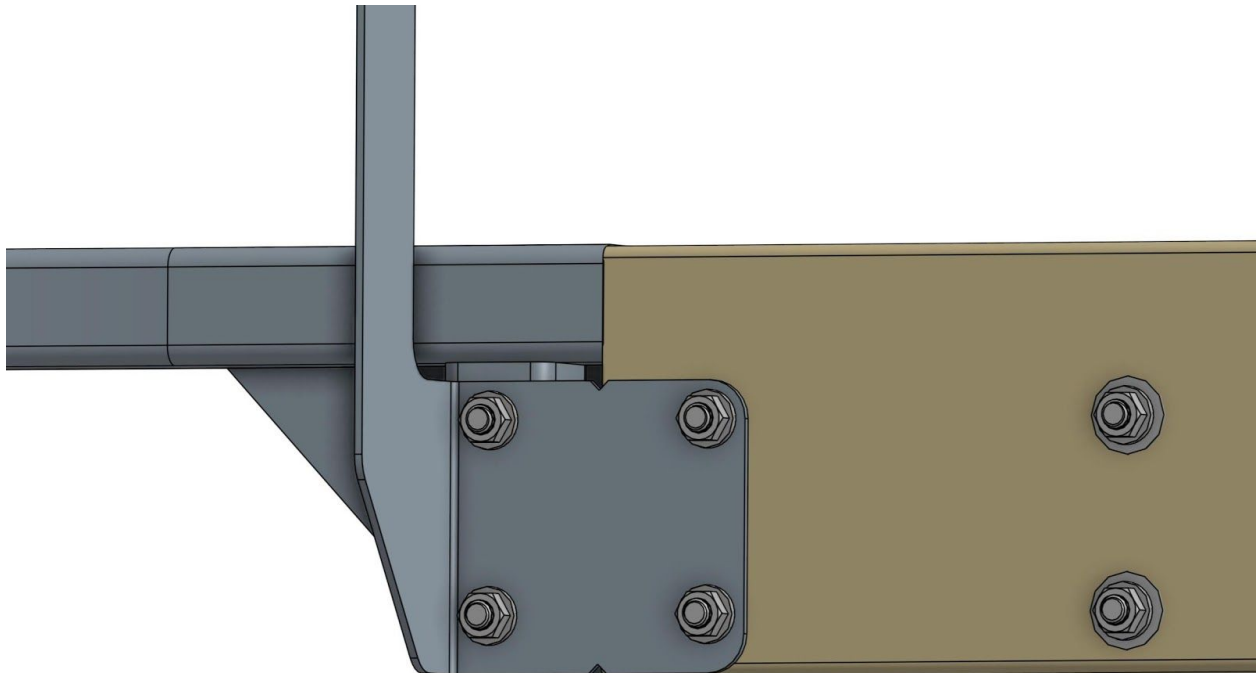

5. Secure the remaining end of the Corner Rail using a Truss Bracket, a Hanger Bracket and a Hanger Extension Bracket. Depending on the pitch of the ceiling, the Hanger Extension Bracket may need to be trimmed so that it doesn't interfere with the Trolley wheel. The image below illustrates how the brackets are assembled.



6. The complete Corner Rail should look like the image below. Install the Corner Rail on the opposite linear rail and then fit the remaining end track into place.



Installing an Adjustable Corner Assembly

The Adjustable Corner Assemblies are available in left and right hand configurations and allow the end track rail of a loop system to be up to 8" higher than the linear track. This creates additional clearance under the end track rail for moving equipment in and out of the house. The orientation of the Adjustable Corner is determined by standing inside the track loop and looking outward. A RIGHT Hand Corner Assembly is used in this illustration.

1. Remove the 3/8" x 2-1/4" carriage bolts from the end Hanger Bracket.
2. Attach pivot end plate of the Adjustable Corner Rail to the Hanger Bracket using (4) 3/8" x 2-1/4" carriage bolts and flange nuts.
3. Drill (2) additional 25/64" holes in the rail using the Corner Rail plate as a template. Attach with (2) 3/8" x 2-1/4" carriage bolts, flat washers and flange nuts.
4. When the pivot end of the Corner Rail is attached to the linear rail, it should appear like the images below.

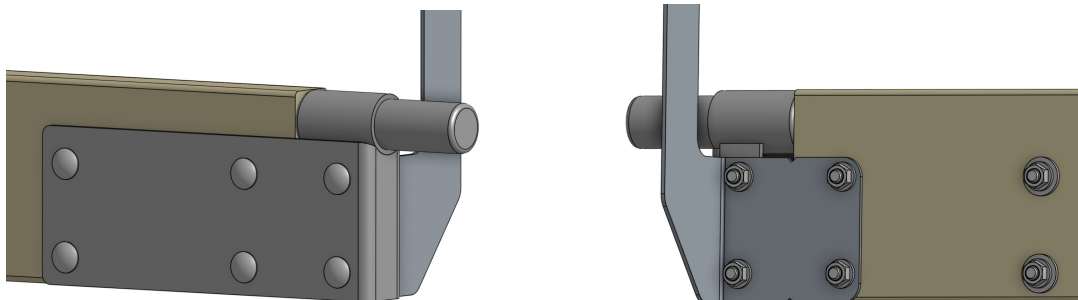

- Slide the Corner assembly over the steel stub shaft of the pivot plate. Adjust the tilt of the Corner until the end track rail plate is at the desired height. Tight the (2) $\frac{1}{2}$ " x 1" bolts to secure the Corner to the stub shaft. **(The height difference of the linear track rail and the end track rail should not exceed 8". An offset of greater than 8" will create too much of an incline for the trolley to function properly.)**

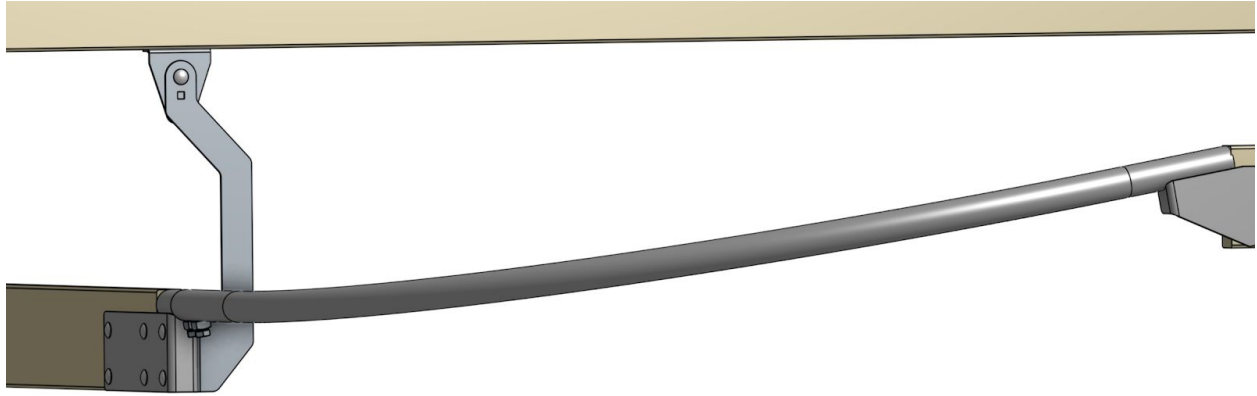

- Attach the 2 X 6 end track rail to the end track rail plate of the corner using (4) $\frac{3}{8}$ " x 2- $\frac{1}{4}$ " carriage bolts, (4) $\frac{3}{8}$ " flat washers and (4) $\frac{3}{8}$ " flange nuts. The end of the 2 X 6 track will need to be miter cut to match the plane of the corner pipe.

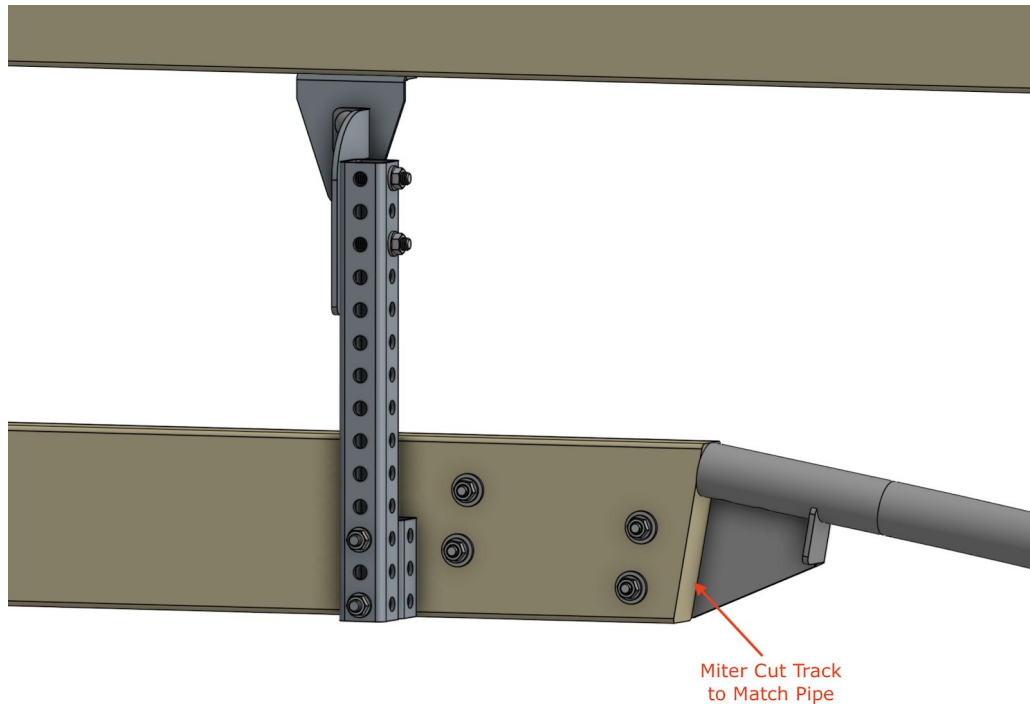

7. Assemble the adjustable track hanger as illustrated below and install directly adjacent to the end track rail plate.

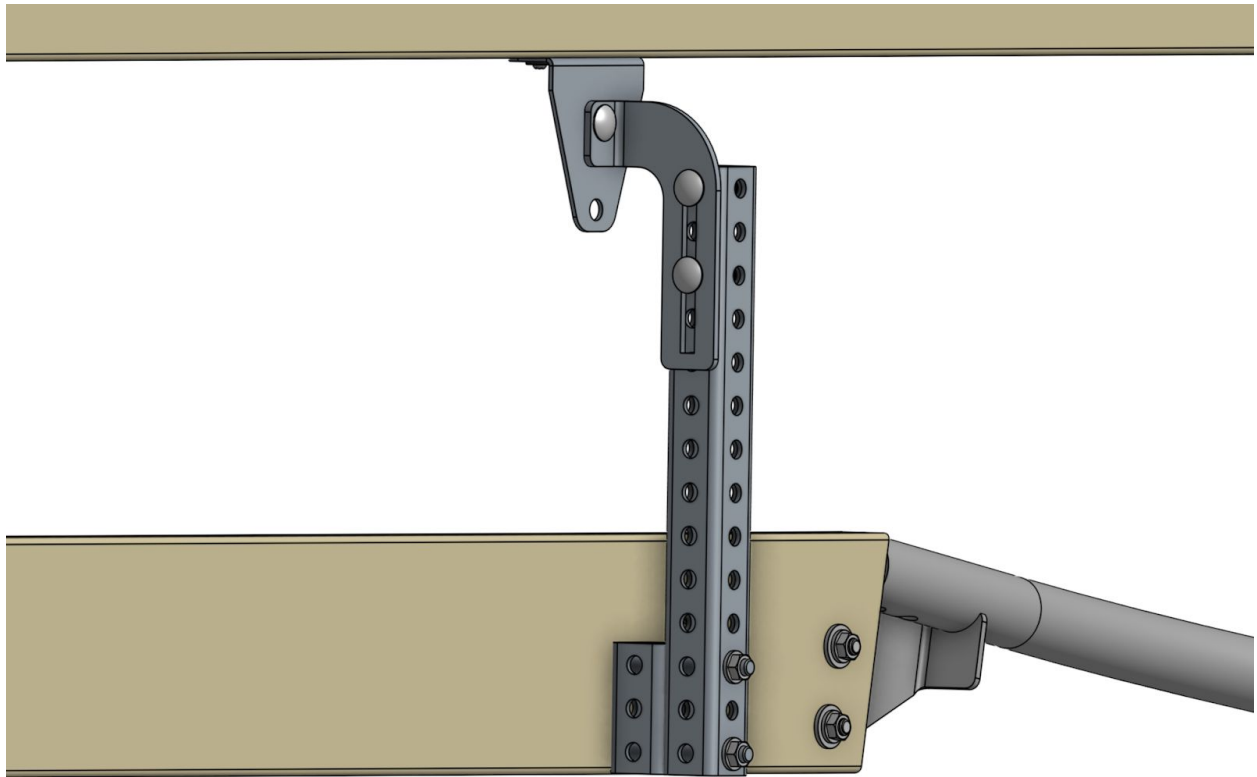

8. View from outside the loop.

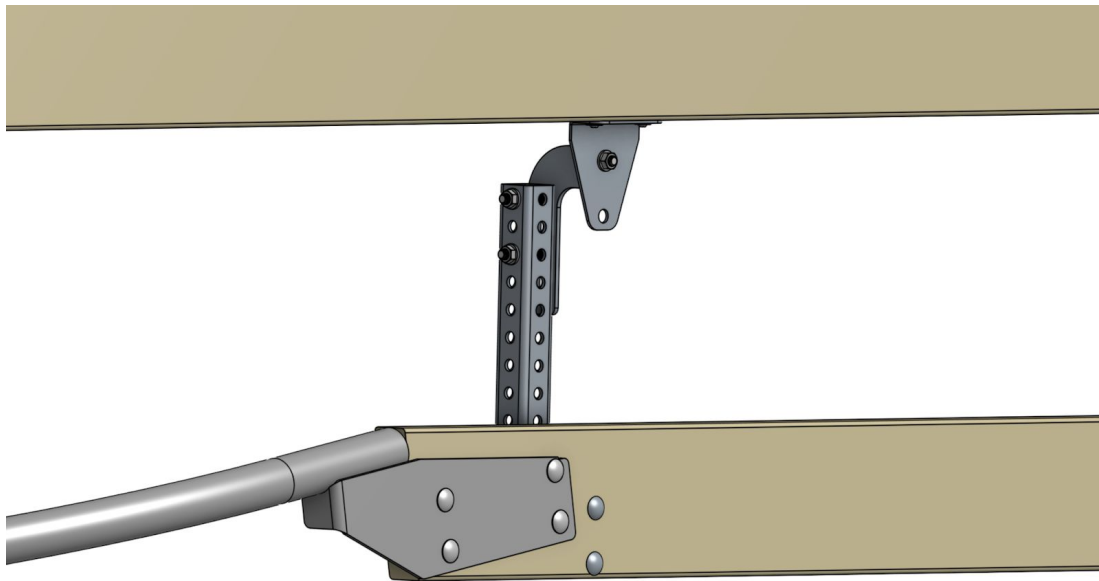

9. Finished view from outside the loop

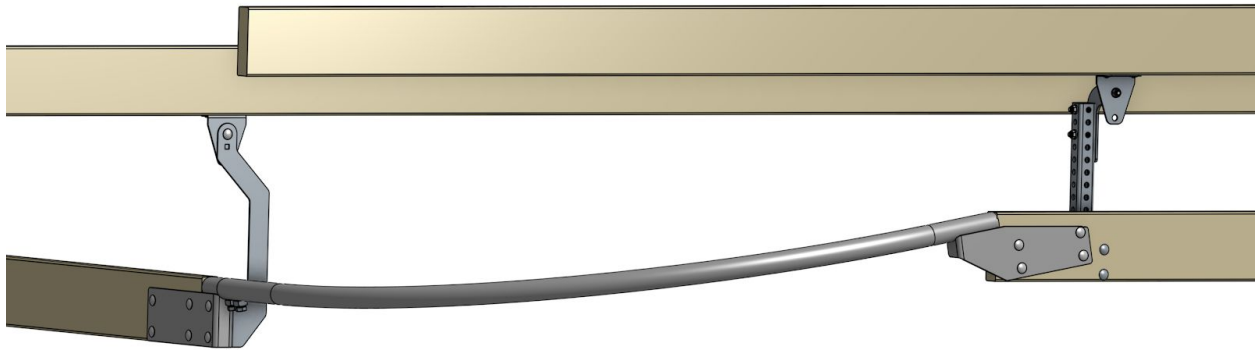

Tool-less Track Bridge

The Track Bridge Kit allows the track to split for houses that have divider curtains. When installed properly, the Bridge can be removed and the Stops flipped down without any tools.

- 1. It generally works best to install the entire track system and then add the Track Bridge last.**
2. Identify the location where the Track Bridge needs to be located to allow the divider curtain to come down.
3. Place the Track Bridge over the track, centered where you will later be removing a 12" long section of track. The notched side of the Track Bridge must be on the same side of the track as the Hanger Brackets are.

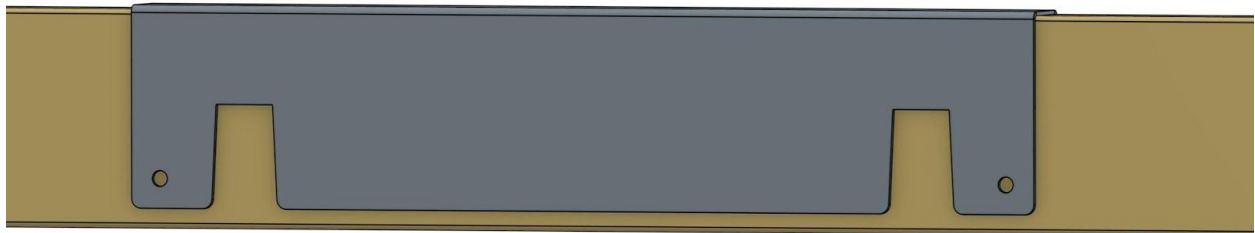

4. Place a Tube Block into the notch and drill (2) 25/64" holes through the wooden rail using the bottom and top hole of the Tube Block as a pilot.
5. Use (2) 3/8" x 5" carriage bolts and flange nuts to secure the Tube Block and Vertical Tube to wooden rail. Ensure that the Vertical Tube is level and tighten.
6. Repeat steps 3-5 for the other side of the bridge.

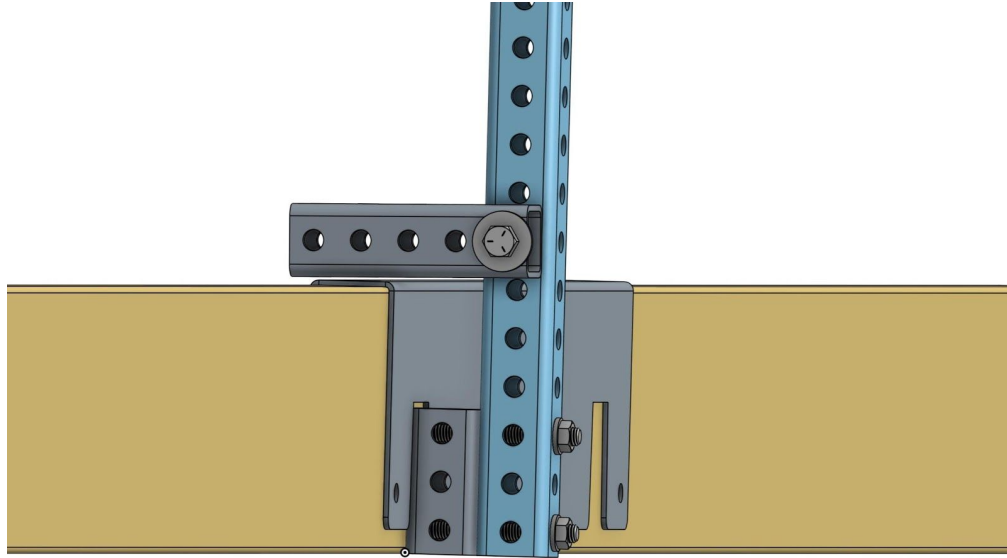

7. Attach an 8' (48" truss centers) or a 10' (60" truss centers) piece of 2" x 6" lumber to the bottom of the trusses to create an attachment point for the Bridge Tubes. The curtain will need to be notched to allow the 2" x 6" to pass through it. Secure the 2" x 6" to the bottom of the (3) trusses using long deck screws.
8. Attach an L Hanger Bracket to each Vertical Tube using (4) 3/8" x 2-1/4" carriage bolts and 3/8" flange nuts. Do NOT tighten yet.
9. Attach a Truss Bracket to each L Hanger Bracket using (2) 3/8" x 3/4" carriage bolts. Use the same (upper or lower) hole that was used on the other Hanger Brackets. Slide the L Hanger Bracket up until the Truss Bracket is against the 2" x 6". Tighten all remaining hardware.
10. Use (4) 5/16" x 2" Construction Lags to secure the (2) Truss Brackets to the 2" x 6".
11. Cut and remove a 12" length of track. This should be centered between the Vertical Tubes. The completed Track Bridge should look like this:

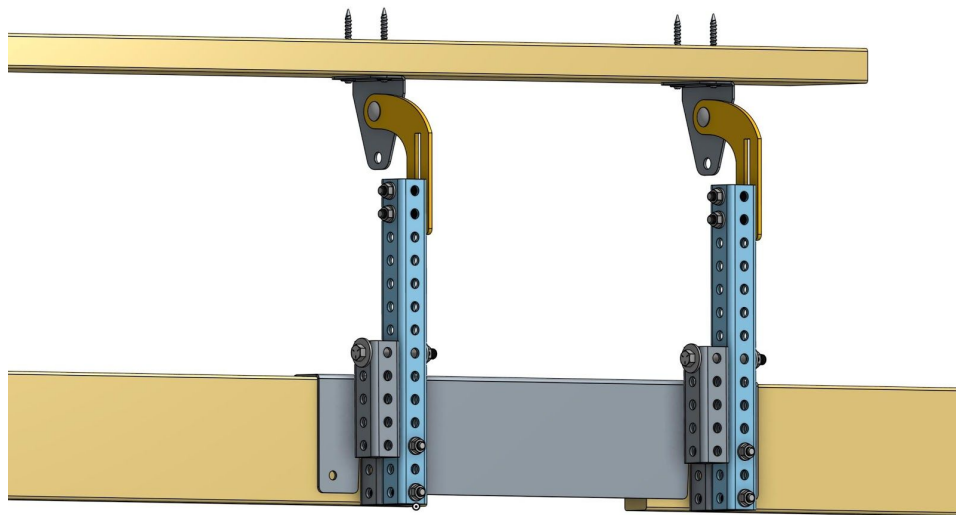

12. When the Track Bridge is removed, flip the End Stop Tubes around so they rest on top of the track. This will prevent the trolley from off the end of the track in the event of an operator error.

WARNING: The End Stop Tubes are intended for emergencies only. NEVER intentionally drive the trolley into the stops as damage to the stop or trolley could occur!

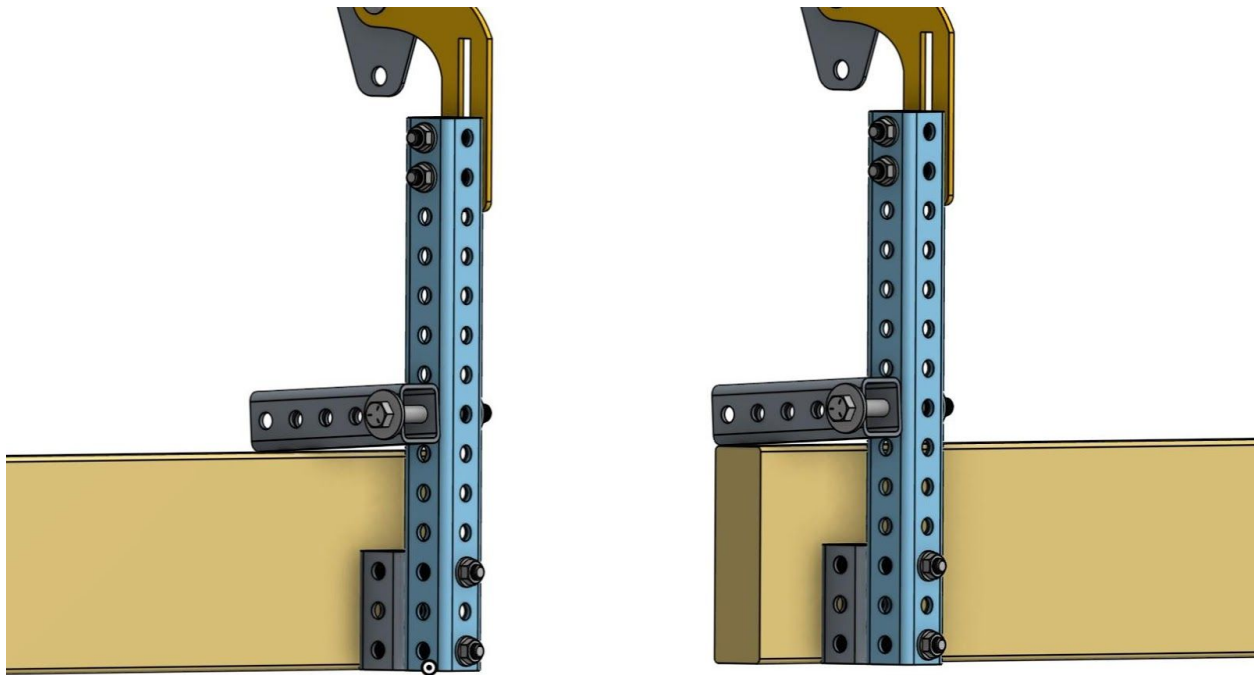

Limit Switch Stop

There is a limit switch below the motor that can be used to always stop the trolley at a certain location. **If you are installing a single rail system, a limit switch stop block must be installed at both ends of the rail to prevent the trolley from running into the End Stop.** The limit switch stop block must be located away from the end of the track far enough so the trolley has time to decelerate before it reaches the End Stop.

Cut a piece of rail lumber to make limit switch stop block. The dimensions of the block should be 1-1/2" wide x 2" tall x 6" long. Drill (2) 5/16" holes through the block and attach it to the bottom of the rail with two GRK fasteners wherever you would like the trolley to stop. The block needs to extend below the track far enough to trigger the limit switch as the trolley moves past.

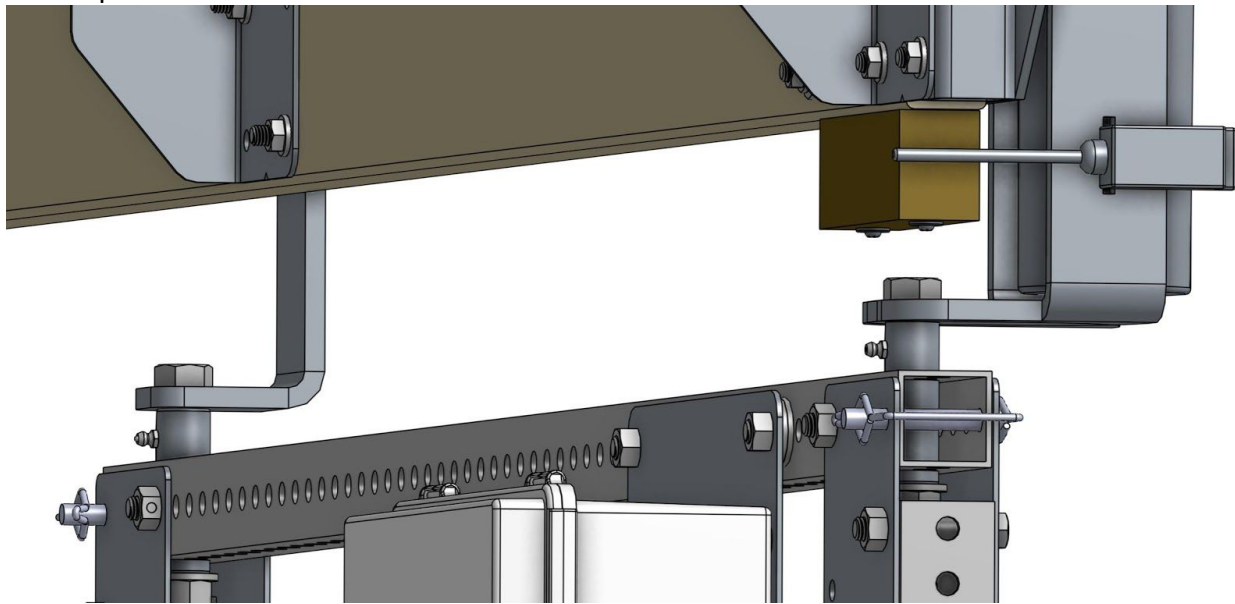

End Stop

On a single rail system, an End Stop MUST be installed at both ends of the track to prevent the trolley from driving off the track in the event of an operator error. The End Stop Tubes are intended for emergencies only. NEVER intentionally drive the trolley into the stops as damage to the stop or trolley could occur!

1. Remove the (2) bolts from the last Hanger Bracket and install the End Stop Plate on the opposite side of the rail from the Hanger Bracket.
2. Install the End Stop Tube in a vertical position using (2) 3/8" x 2-1/4" carriage bolts and 3/8" flange nuts.
3. Drill (2) 25/64" holes in the wooden rail and install (2) more 3/8" x 2-1/4" carriage bolts, 3/8" flat washers and 3/8" flange nuts. The completed End Stop should look like this.

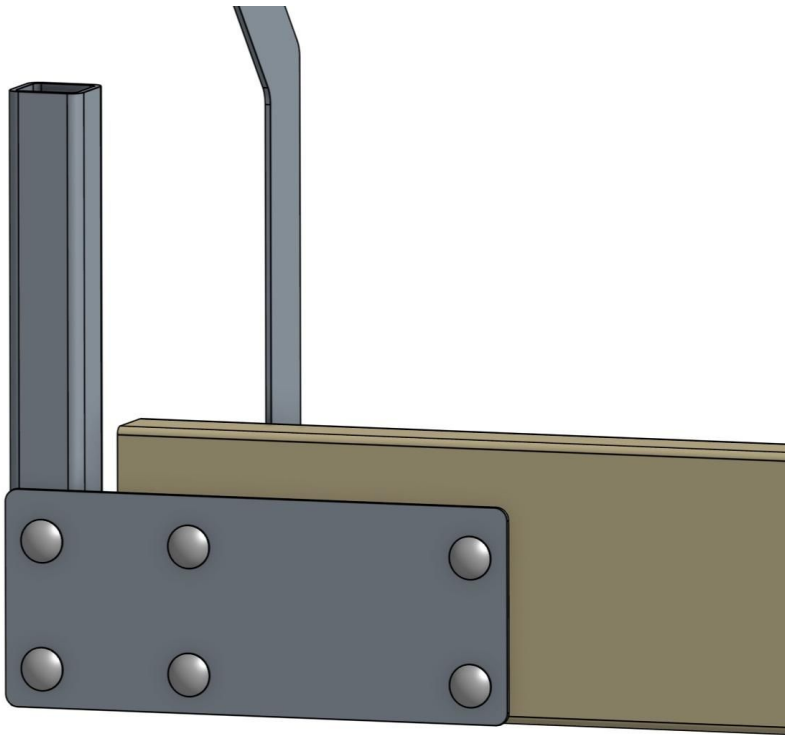
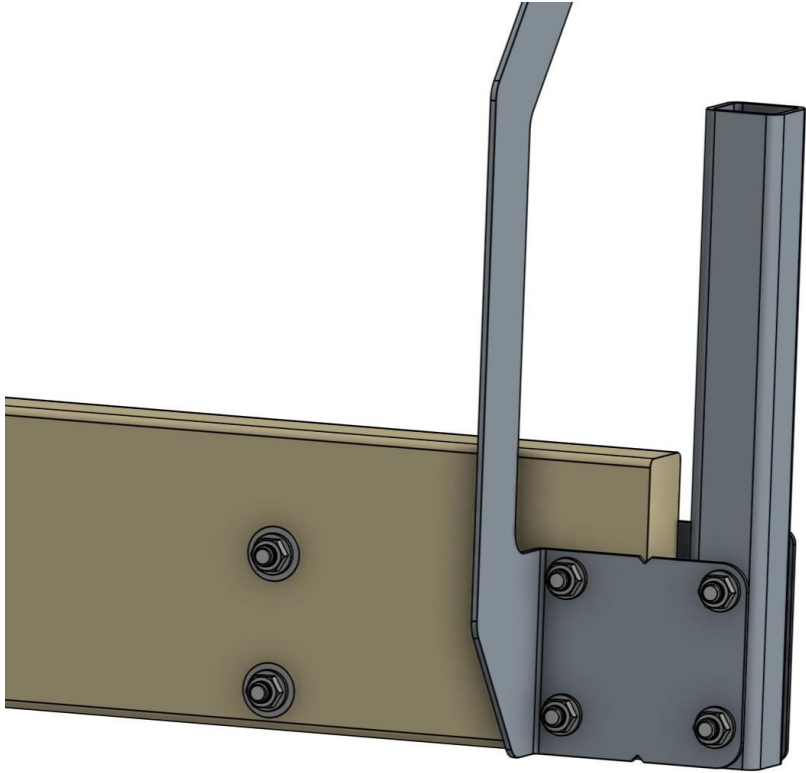

Installing the Trolley

The Chicken Reaper trolley hangs on the rail system. Carefully lift the up trolley and place the wheels over the rail. The wheel brackets must always be on the opposite side of the track rail from the Hanger Brackets are.

Remove the clip pins from the upper telescopic tubes and swing them down. Reinstall the clip pins to lock the tubes into place.

Use the clip pins on the telescopic tubes to set the height of the dump box or bucket tray.

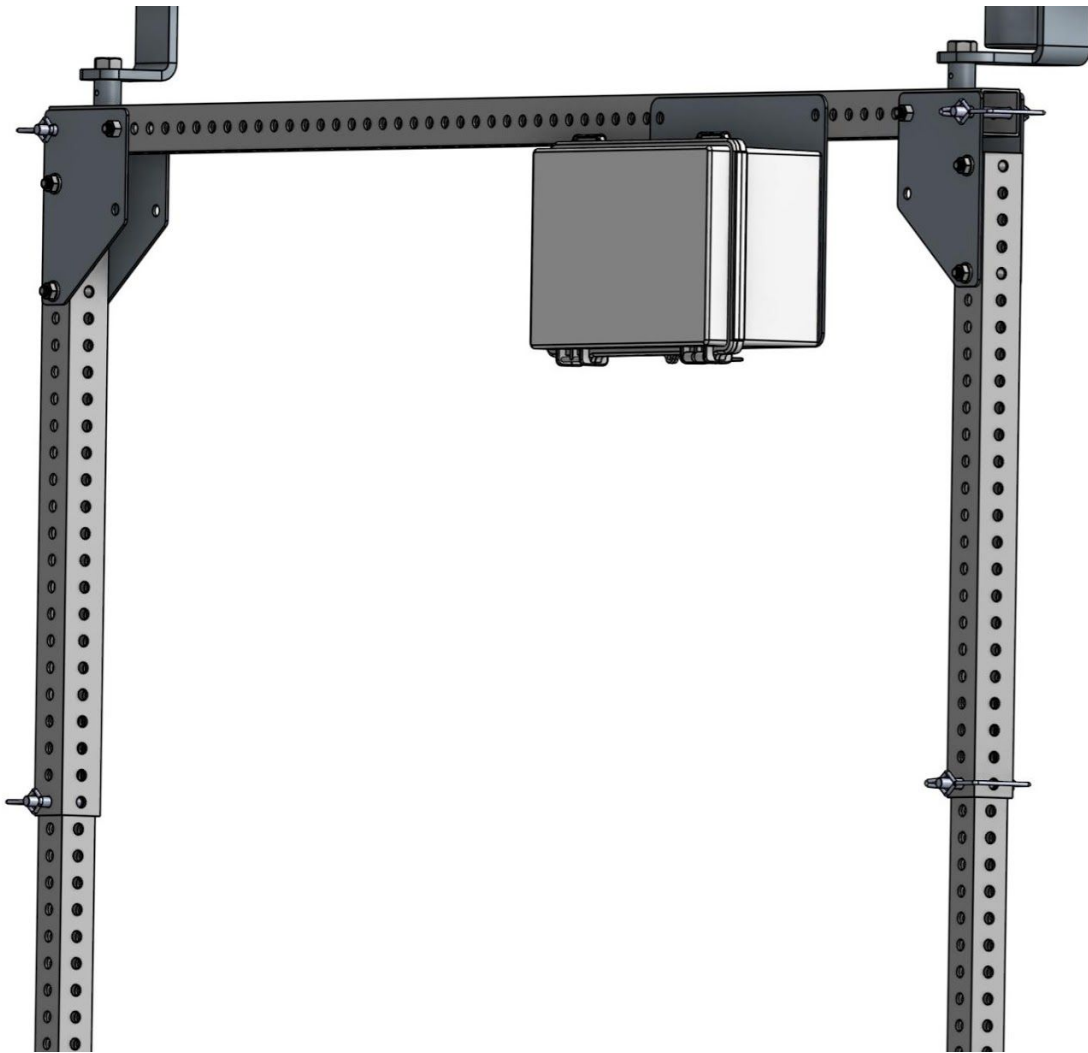

Operation

Press the ON button on the Pendant Switch. Use the provided remote control transmitter to operate the trolley. When you are finished using the Chicken Reaper, always turn the Pendant Switch to OFF to avoid draining the battery.

CAUTION

When operating the Chicken Reaper on a loop system, DO NOT navigate a corner at more than 50% speed. Operating the Chicken Reaper too fast around a corner may cause the trolley to swing side to side increasing the risk of damage to the Chicken Reaper and/ or nearby equipment. Always slow the travel speed of the Chicken Reaper to 50% or less when approaching a corner!

Charging the Battery

The Chicken Reaper is equipped with a Lithium Ion battery pack. The operating time on a single charge will range from 1-3 hours and in most applications the battery will need to be recharged every 4-5 days. Factors like the length of the track, the speed of travel and the weight of the load will affect how long the Chicken Reaper will run before it needs to be recharged. The battery meter located on the side of the control box will indicate the remaining charge in the battery.

To charge the battery, ensure that the Pendant Switch is ON and then attach a 115 volt power cord to the charger cord above the Pendant Switch. The charger is automatic and will shut off when the battery is completely charged. Average charging time is about 6 hours. Unplug the 115 volt power cord before attempting to use the Chicken Reaper again.

Maintenance

1. Inspect the track and trolley periodically for any loose hardware.
2. Grease the wheel swivel points and the idler wheel bearing after every 30 hours of use.
3. Replace the remote transmitter battery whenever the effective distance is reduced. The battery is an A23 alkaline battery that is widely available.

Programing the Remote

1. Each remote is linked to a specific trolley. To link a new remote to a trolley, follow the instructions below.
 - a. Open the gray control box and locate the receiver circuit board.
 - b. Locate the pushbutton switch labeled "PROGRAM" on the upper right-hand side of the receiver circuit board. Press and hold this switch until the red LED next to the program switch illuminates (approximately 3 seconds). The receiver is now in the transmitter program mode, release the switch. At this point, all previously programmed transmitter addresses are erased from the receiver's memory.
 - c. Within 5 seconds, press and release the UP ARROW on the transmitter. The red LED will blink once.
 - d. Press and release the UP ARROW on the transmitter a second time. The red LED will blink rapidly.

- e. Wait 5 seconds for the receiver to return to normal operation. The red LED will go out.
- f. The transmitter and receiver are now paired and the trolley is ready to operate.

Warranty Coverage

Plum Creek Farm LLC hereby provides a Limited One (1) Year Warranty on the Products manufactured by Plum Creek Farm LLC that such Products shall be free from manufacturer's defects in any of the Product's components in the 12 month period following the original date of purchase from the authorized dealer (the "Warranty Period"). Plum Creek Farm LLC HEREBY EXCLUDES AND DISCLAIMS ANY AND ALL OTHER WARRANTIES, STATUTORY, EXPRESS OR IMPLIED, INCLUDING WITHOUT LIMITATION ANY IMPLIED WARRANTY OF MERCHANTABILITY OR FITNESS FOR ANY PARTICULAR PURPOSE AND ANY WARRANTY ARISING FROM USAGE OF TRADE OR COURSE OF DEALING. Defective components will be repaired or replaced at the discretion of the manufacturer. It is the responsibility of the purchaser to return warranted components to the manufacturer. This Product Warranty is limited to INCIDENTAL OR CONSEQUENTIAL DAMAGES OF ANY KIND. This Product Warranty covers the purchaser of this Product and any other owners who own it during the Warranty Period. To retain the Product Warranty, the Product must be operated and maintained as set forth by its owner's manual. For warranty service, please have a copy of the purchase invoice available.

Warranty Is Void If:

1. The Product has been subjected to, in the opinion of Plum Creek Farm LLC, negligent handling, misuse, an accident or if the instructions in the owner's manual were not completely followed.
2. The Product's components have been altered in any manner, not installed per the Manufacturer's instructions, or repairs have taken place with unapproved parts.

Getting Warranty Service

All Product Warranty claims must be made through an authorized Plum Creek Farm LLC dealer. All warranty claims must be submitted with an invoice or a proof of purchase that denotes the purchase date and place of purchase. If you have any questions or comments concerning this warranty, please contact Plum Creek Farm LLC or an authorized Plum Creek Farm LLC dealer.

Contact Information

Plum Creek Farm LLC
626 Plum Creek Rd
Leesport, PA 19533
www.plumcreekmfg.com
info@plmcrk.com
(484) 509-1571